

Fire Rated Window and Door System

CLASSIFICATION



PRODUCT DESCRIPTION

VDS LITE is a narrow style framing system that meets fire ratings from 20 to 90 minutes. This non-insulated system provides architects with modern and innovative design opportunities where a fire rating is required. VDS LITE is easy to assemble, reducing installation time and cost compared to other conventional door and window systems.

TECHNICAL SPECIFICATIONS

Meets/Compliant	NFPA 80, NFPA 251, NFPA 252, UL 9, UL 10B, UL 10C
Finish Option	Powder Coat / Enamel
Custom Colors ¹	Yes
Fabrication	Welded
Certification	Underwriters Laboratories
Fabricated in the US	Yes
Glazing Options	SGGKERALITE [®] 20-90, SGGSWISSFLAM [®] 45, SGGCONTRAFLAM [®] 60
Single/Double Doors	Yes
Weight (lbs/lin.ft.)	1.8 - 2.13
Max Door Leaf Size	42" x 96"

DETAILS

VDS LITE Perimeter

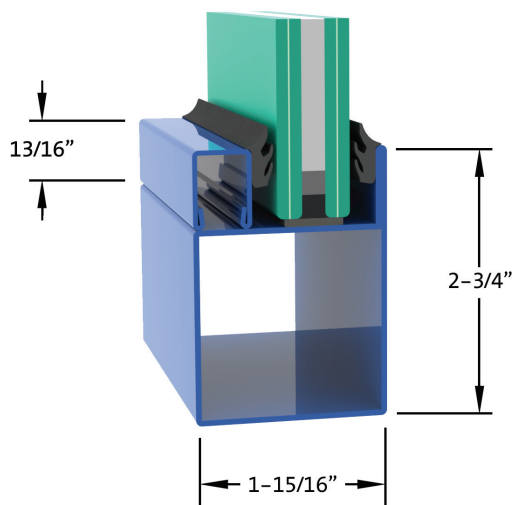

VDS LITE Mullion

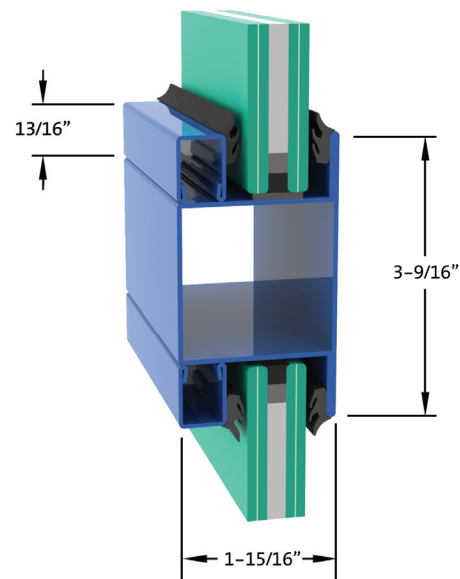

¹ Surcharge May Apply

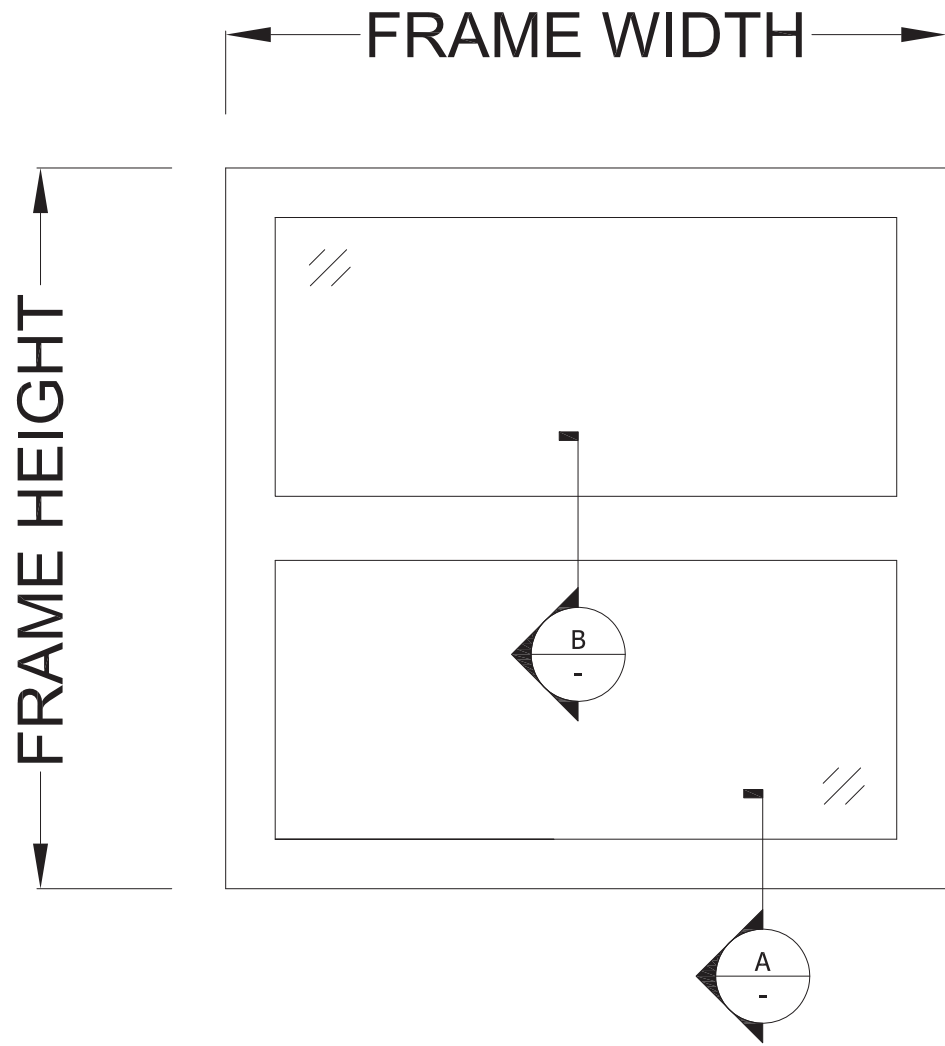

vetrotech
SAINT-GOBAIN

2108 B STREET NW
SUITE 110
AUBURN, WA 98001

PHONE: 888.803.9533
FAX: 253.333.5166
www.vetrotechusa.com

DESCRIPTION

VDS 60 LITE ELEVATION

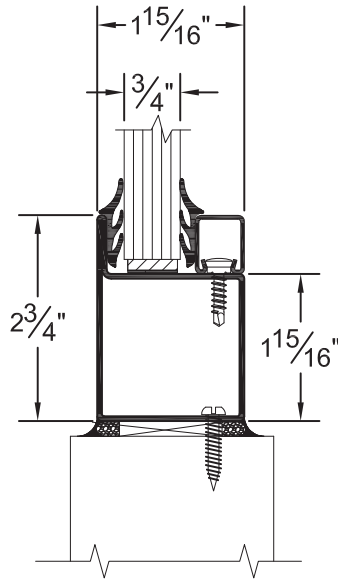

A

TYPICAL VDS LITE PERIMETER DETAIL

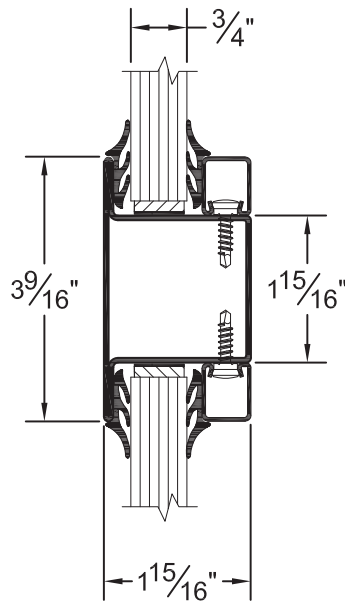

B

TYPICAL VDS LITE MULLION DETAIL

vetrotech
SAINT-GOBAIN

2108 B STREET NW
SUITE 110
AUBURN, WA 98001
PHONE: 888.803.9533
FAX: 253.333.5166
www.vetrotechusa.com

DESCRIPTION

VDS 20/45/60/90 LITE PERIMETER
AND MULLION DETAILS