



CERTIFICATE OF APPROVAL
No CF 684

This is to certify that, in accordance with
TS00 General Requirements for Certification of Fire Protection Products
The undermentioned products of

VETROTECH SAINT GOBAIN INTERNATIONAL

Stauffacherstrasse 128, CH-3000 Bern 22, Switzerland
Tel: +41 313368181 Fax: +41 313368119
Website: www.vetrotech.com

Have been assessed against the requirements of the Technical Schedule(s)
denoted below and are approved for use subject to the conditions
appended hereto:

CERTIFIED PRODUCT

TECHNICAL SCHEDULE

**SGG Pyroswiss Fire Resisting
Glass**

**TS 25 Fire Resistant Glass,
Glazing Systems and Materials**

Signed and sealed for and on behalf of CERTIFIRE

Sir Ken Knight
Chairman - Management Council

Issued: 12th May 2009
Revised: 29th October 2009
Valid to: 11th May 2014



Page 1 of 14





CERTIFICATE No CF 684
VETROTECH SAINT-GOBAIN INTERNATIONAL

SGG PYROSWISS FIRE RESISTING GLASS

This Certificate of Approval relates to the fire resistance of SGG Pyroswiss glass when used in the following applications, as defined in BS 476: Part 22: 1987 subject to the undermentioned conditions.

Application	Fire Resistance Performance Integrity - (mins)	Page No.
Timber Doorsets	30	4
Double Glazed Units in Timber doorsets	30	5
Timber Screens	30	7
Double Glazed Units in Timber Screens	30	8
Steel Doorsets	30	9
Double Glazed Units in steel doorsets	30	10
Steel Screens	30	11
Double Glazed Units in Steel Screens	30	13

This product is approved on the basis of:

- i) Initial type testing.
- ii) A design appraisal against TS25.
- iii) Certification of quality management system to ISO 9001: 2008.
- iv) Inspection and surveillance of factory production control.
- v) Audit testing.

This Certificate of Approval must be read in conjunction with CERTIFIRE Technical Schedule TS25, Fire Resistant Glass, Glazing Systems and materials.

General Requirements

Where the glass is installed in a timber or steel framed screen, the orientation of the screen shall be no more than $\pm 10^\circ$ from the vertical.

There is no restriction to the direction of exposure for the glass i.e. the glass is symmetrical. Orientation may, however, be restricted by the requirements of a non-symmetrical framing system or certain double glazed unit specifications.

The edge cover to each pane shall be 8 mm for timber door and screen applications and 10 mm for steel door and screen applications.

The glass is approved in a nominal thickness of 6, 8, 10, 12 and 15 mm (depending on application).

Page 2 of 14 Signed

Issued: 12th May 2009
Revised: 29th October 2009
Valid to: 11th May 2014



CERTIFICATE No CF 684
VETROTECH SAINT-GOBAIN INTERNATIONAL

SGG PYROSWISS FIRE RESISTING GLASS

Acid Etching, Tinting, Screen Printing and Patterned Glass

The SGG Pyroswiss glass (6,8,10,12 or 15 mm thick) may be provided with surface finishes including acid etching, tinting, screen printing and patterned both single and double glazed systems. The printing may account for any area of the glass.

The reference for these type of glass are as follows:

- Acid etched – SGG Pyroswiss Satinovo
- Tinted – SGG Pyroswiss Parsol
- Patterned – SGG Pyroswiss Mastercarre
- Screen printed - SGG Pyroswiss Serallt

Laminated Glass

The SGG Pyroswiss glass (6, 8, 10, 12 or 15 mm thick, depending on application) may be laminated to float or toughened glass having a minimum thickness of 4 mm and a maximum thickness of 8 mm using a PVB interlayer with 0.38 mm minimum thickness and 1.52 mm maximum thickness with the laminated glass unit orientated such that the SGG Pyroswiss glass faces the side of the assembly to be fire protected (i.e SGG Pyroswiss to non-fire risk side). Where this side is not known, laminated glass utilising a toughened glass layer shall not be used.

The SGG Pyroswiss glass (6, 8, 10, 12 or 15 mm thick, depending on application) may be laminated to a SGG Pyroswiss glass having a minimum thickness of 6 mm and a maximum thickness of 15 mm using a PVB interlayer with 0.38 mm minimum thickness and 1.52 mm maximum thickness. Laminated glass of this specification may be used without limit on the exposure direction.

The SGG Pyroswiss glass, when laminated as described above, may be used in any timber or steel framed assemblies for up to 30 minutes integrity as covered by this certificate.

Double Glazed Units (DGU's)

The SGG Pyroswiss DGU glass may be assembled with either aluminium or steel spacer bars (6 mm minimum). The SGG Pyroswiss DGU glass may be composed of two panes of SGG Pyroswiss 6 mm when the fire risk is known to be from either side. Alternatively, if the fire risk side is known, the DGU may comprise one pane of SGG Pyroswiss 6 mm and one pane of any type (including toughened, float, laminated, coated, acid etched, patterned or screen printed). In this case the SGG Pyroswiss glass MUST be positioned to the non-fire risk side of the element.

Applied Films

Adhesive/adherent polyester/polyethylene terephthalate (PET) or polyvinyl Chloride (PVC) films may be applied to the free vision area of a glazed element. They may have a thickness between 25 and 250 µm. The applied film MUST be positioned to the fire risk side of the element.



CERTIFICATE No CF 684
VETROTECH SAINT-GOBAIN INTERNATIONAL

SGG PYROSWISS FIRE RESISTING GLASS

SGG Pyroswiss Glass in timber door leaves for periods of 30 minutes integrity

The glass shall be glazed within a previously fire tested or CERTIFIRE approved timber based doorset utilising the following basic specification:

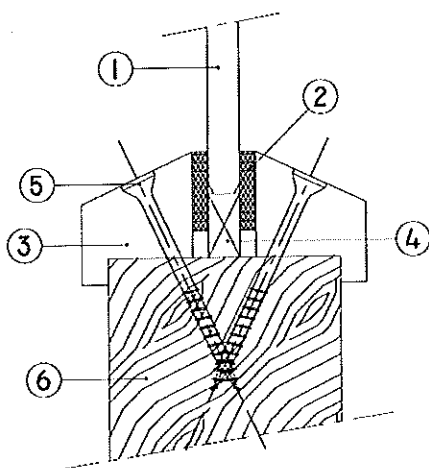

- ① SGG PYROSWISS 6 to 15 mm (edge-cover 8 mm)
- ② 15 x 3 mm Hodgsons Sealants Firetape Ceramic
- ③ 25 x 21 mm (h x w) hardwood glazing beads minimum density 650 kg/m³ (including 5 x 5 mm (h x w) bolection with 25° chamfer)
- ④ Non-combustible / hardwood setting blocks glass thickness x 12 x 80 mm (w x h x d) (2 pieces per glass, on the bottom only)
- ⑤ 50 mm long steel screws at 130 mm centres (30° to glass)
- ⑥ Nominally 44 mm thick FD30 door leaf

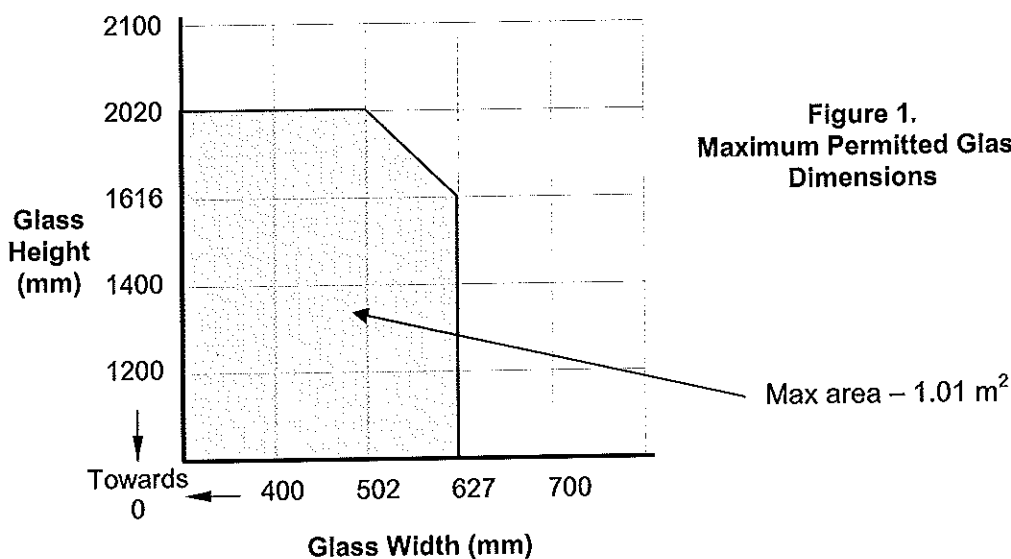



CERTIFICATE No CF 684
VETROTECH SAINT-GOBAIN INTERNATIONAL

SGG PYROSWISS FIRE RESISTING GLASS

SGG Pyroswiss Glass (Double Glazed Units) in timber door leaves for periods of 30 minutes integrity

The glass shall be glazed within a previously fire tested or CERTIFIRE approved timber based doorset utilising the following basic specification:

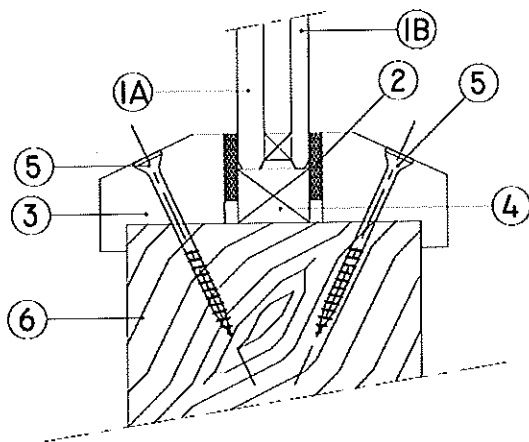

- ①A SGG PYROSWISS 6 mm (edge-cover 8 mm)
- ①B Glass used subject to the conditions specified page 3 (Double Glazing Unit - DGU)
- ② 15 x 3 mm Gluske Kerafix (compressed to 2.5 mm)
- ③ 26 x 28.5 mm (h x w) hardwood glazing beads minimum density 700 kg/m³ (including 6 x 6 mm (h x w) bolection where applicable with 25° chamfer minimum)
- ④ Non-combustible / hardwood settling blocks glass thickness x 12 x 80 mm (w x h x d) (2 pieces per glass, on the bottom only)
- ⑤ 40 mm long steel screws at 150 mm centres (30° to glass)
- ⑥ Nominally 82 mm thick FD30 door leaf

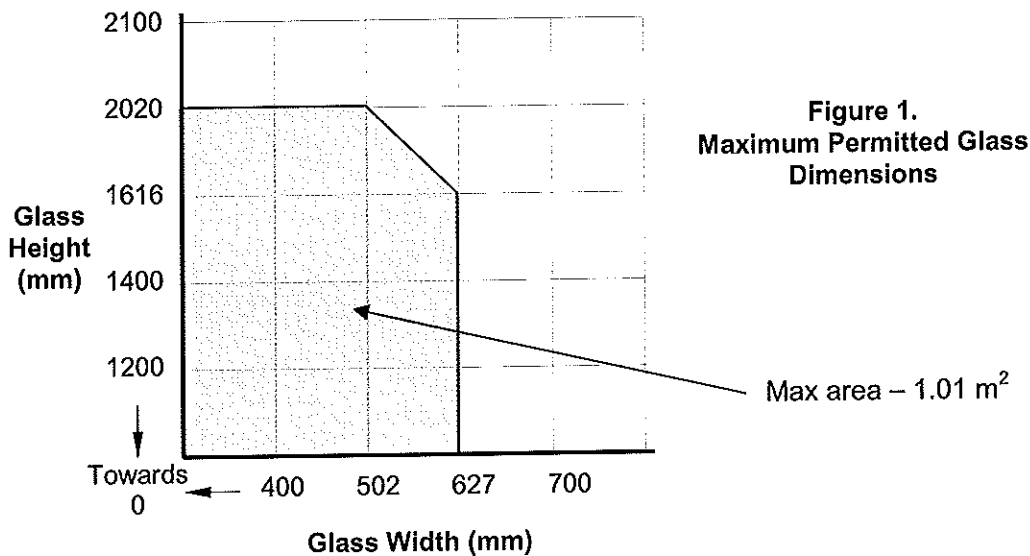



CERTIFICATE No CF 684
VETROTECH SAINT-GOBAIN INTERNATIONAL

SGG PYROSWISS FIRE RESISTING GLASS

SGG Pyroswiss Glass in timber door leaves for periods of 30 minutes integrity

For this application, the following conditions shall apply:

1. The doorset, including door frame and associated building hardware, should have achieved at least 30 minutes integrity when tested, or subsequently assessed by one of the laboratories approved by CERTIFIRE as acceptable for this purpose, to BS 476: Part 22: 1987 or BS EN 1634-1: 2000.
2. If the proposed doorset is to be used in double-leaf configuration, the test or assessment evidence should be applicable to double-leaf configurations.
3. Likewise, if the proposed doorset is to be used in the unlatched configuration, the available evidence should be applicable to unlatched doorsets.
4. The proposed doorset should also have included a glazed aperture or apertures of the intended size, shape, area and number.
5. When used to glaze CERTIFIRE approved doorsets which have smaller apertures than allowed in this certificate, the aperture sizes specified in the doorset certificate shall take precedence.
6. The door leaves shall consist of timber faces coupled with timber or other cellulosic cores of minimum overall leaf thickness, 44 mm.
7. When an alternative CERTIFIRE approved glazing system is used, the system shall have been shown to be capable of including SGG Pyroswiss glass. The maximum permitted aperture dimensions shall be as detailed below or included within the relevant CERTIFIRE certificate for the glazing system, whichever is the lesser.
8. Other CERTIFIRE approved glazing seals may be acceptable subject to the limitations within the relevant certificate. This Certificate of Approval relates to the sizes of SGG Pyroswiss glass shown in Figure 1 above, when used in conjunction with above system. The aspect ratio of the glass may be unlimited within these aperture dimensions.

Note: glass used in this application may be laminated, acid etched, tinted, patterned or screen printed subject to the conditions specified on Page 3 of this document.

A handwritten signature in black ink, appearing to be "K. J. ...".



CERTIFICATE No CF 684
VETROTECH SAINT-GOBAIN INTERNATIONAL

SGG PYROSWISS FIRE RESISTING GLASS

SGG Pyroswiss Glass in timber framed screens for periods of 30 minutes integrity

The glass shall be glazed utilising the following basic specification:

The screens shall be no greater than 4000 mm high unless suitable tie backs and/or fire protected structural supports are provided.

Note: glass used in this application may be laminated, acid etched, tinted, patterned or screen printed subject to the conditions specified on Page 3 of this document.

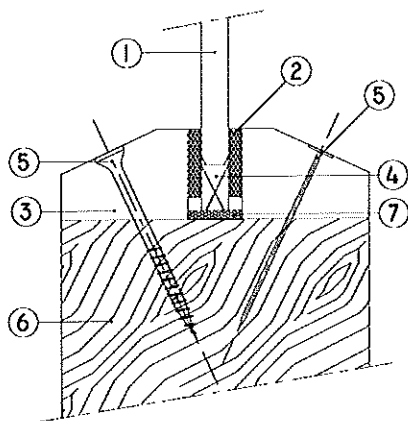

- ① SGG PYROSWISS 6 to 15 mm (edge-cover 8 mm)
- ② 15 x 3 mm Gluske Kerafix (compressed to 2.5 mm)
- ③ 20 x 28.5 mm (h x w) hardwood glazing beads minimum density 700 kg/m³ (with 25° chamfer minimum)
- ④ Non-combustible / hardwood setting blocks glass thickness x 12 x 80 mm (w x h x d) (2 pieces per glass, on the bottom only)
- ⑤ 60 mm long steel pins or screws at 150 mm centres (30° to glass)
- ⑥ 68 x 40 mm minimum hardwood frame minimum density 700 kg/m³
- ⑦ 11 x 2 mm Gluske Blahppler Intumescent impregnated ceramic fibre (used in conjunction setting blocks)

Other CERTIFIRE approved glazing seals may be acceptable subject to the limitations within the relevant certificate. This Certificate of Approval relates to the sizes of SGG Pyroswiss glass shown in Figure 2 below, when used in conjunction with above system. The aspect ratio and shape (rectilinear only) of the glass may be unlimited within these aperture dimensions.

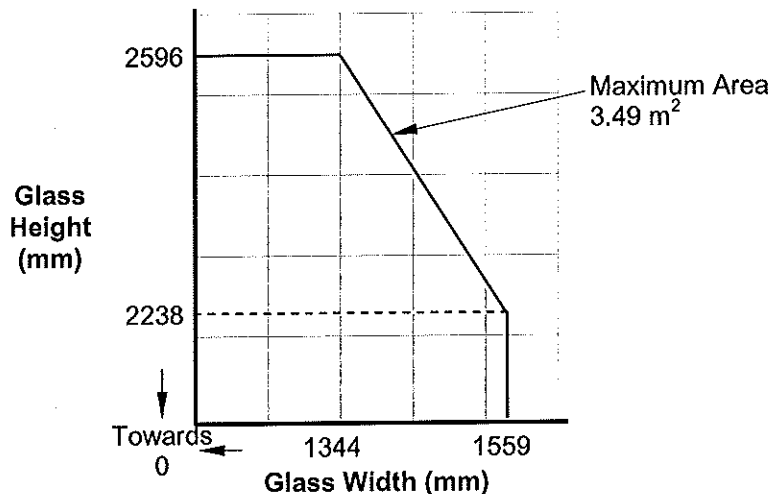

Figure 2.
Maximum Permitted Glass Dimensions



CERTIFICATE No CF 684
VETROTECH SAINT-GOBAIN INTERNATIONAL

SGG PYROSWISS FIRE RESISTING GLASS

SGG Pyroswiss Double Glazed Units (DGU's) Glass in timber framed screens for periods of 30 minutes integrity

The glass shall be glazed utilising the following basic specification:

The screens shall be no greater than 4000 mm high unless suitable tie backs and/or fire protected structural supports are provided.

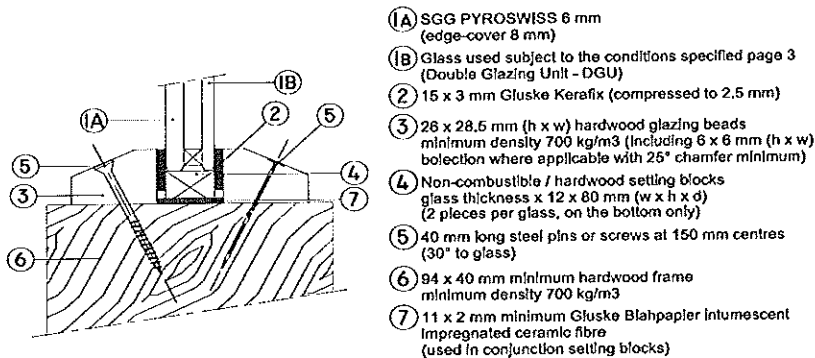

Note: glass used in this application may be laminated, acid etched, tinted, patterned or screen printed subject to the conditions specified on Page 3 of this document.

Other CERTIFIRE approved glazing seals may be acceptable subject to the limitations within the relevant certificate. This Certificate of Approval relates to the sizes of SGG Pyroswiss glass shown in Figure 3 below, when used in conjunction with above system. The aspect ratio and shape (rectilinear only) of the glass may be unlimited within these aperture dimensions.

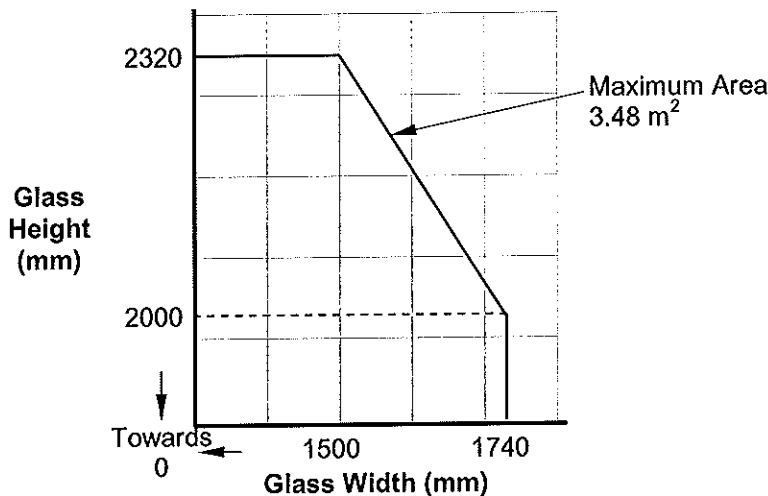

Figure 3.
Maximum Permitted Glass Dimensions



CERTIFICATE No CF 684
VETROTECH SAINT-GOBAIN INTERNATIONAL

SGG PYROSWISS FIRE RESISTING GLASS

SGG Pyroswiss Glass in steel doorsets for periods of 30 minutes integrity

The glass shall be glazed within a previously fire tested (see example below) or a CERTIFIRE approved steel profiled door leaf framing system.

Note: glass used in this application may be laminated, acid etched, tinted, patterned or screen printed subject to the conditions specified on Page 3 of this document.

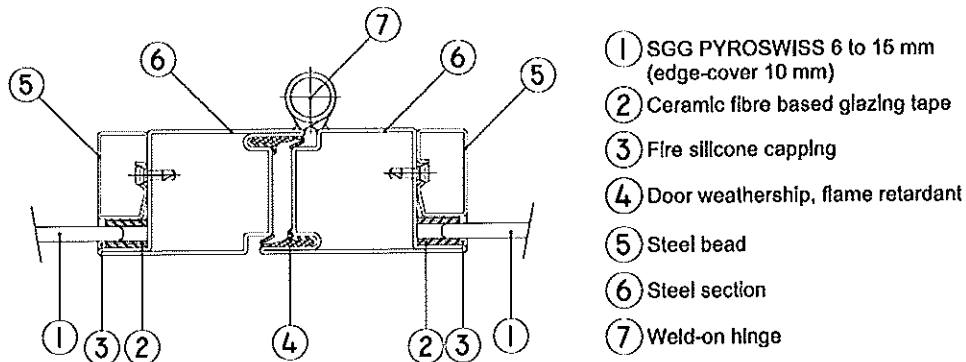

The steel profiled door framing system shall have test evidence (such as JANSEN ECONOMY 50) or be CERTIFIRE approved for the inclusion of apertures of the proposed dimensions. If the proposed doorset is to be used in double-leaf configuration, the test or assessment evidence should be applicable to double-leaf configurations. Likewise, if the proposed doorset is to be used in the unlatched configuration, the available evidence should be applicable to unlatched doorsets. When used to glaze CERTIFIRE approved doorsets which have smaller apertures than allowed in this certificate, the aperture sizes specified in the doorset certificate shall take precedence.

This Certificate of Approval relates to the sizes of SGG Pyroswiss glass shown in Figure 4 below, when used in conjunction with the above system. The aspect ratio and shape (rectilinear only) of the glass may be unlimited within these aperture dimensions.

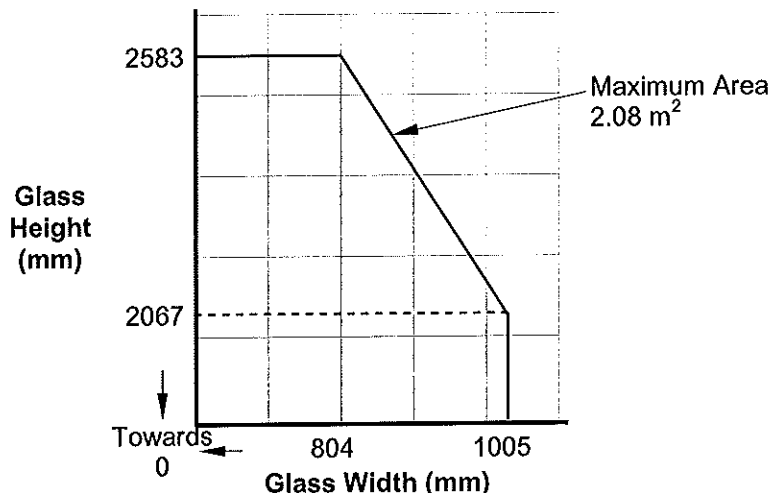

Figure 4.
Maximum Permitted Glass Dimensions



CERTIFICATE No CF 684
VETROTECH SAINT-GOBAIN INTERNATIONAL

SGG PYROSWISS FIRE RESISTING GLASS

SGG Pyroswiss Double Glazed Units (DGU's) in steel doorsets for periods of 30 minutes integrity

The glass shall be glazed within a previously fire tested (see example below) or a CERTIFIRE approved steel profiled door leaf framing system.

Note: glass used in this application may be laminated, acid etched, tinted, patterned or screen printed subject to the conditions specified on Page 3 of this document.

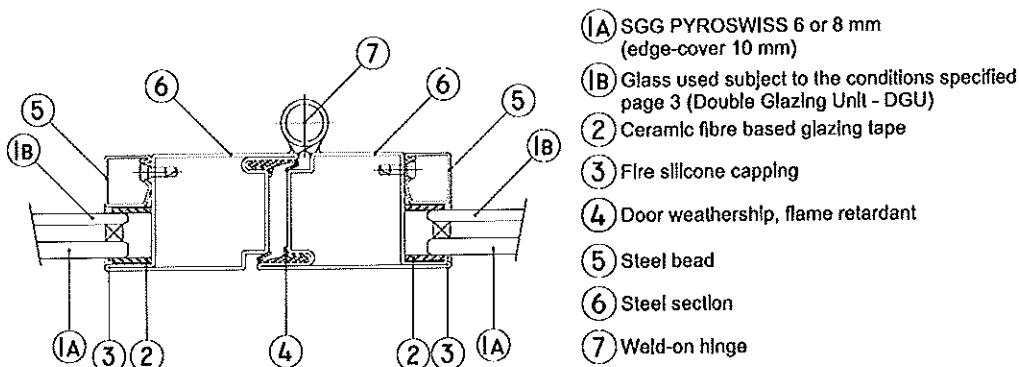

The steel profiled door framing system shall have test evidence (such as JANSEN ECONOMY 50) or be CERTIFIRE approved for the inclusion of apertures of the proposed dimensions. If the proposed doorset is to be used in double-leaf configuration, the test or assessment evidence should be applicable to double-leaf configurations. Likewise, if the proposed doorset is to be used in the unlatched configuration, the available evidence should be applicable to unlatched doorsets. When used to glaze CERTIFIRE approved doorsets which have smaller apertures than allowed in this certificate, the aperture sizes specified in the doorset certificate shall take precedence.

This Certificate of Approval relates to the sizes of SGG Pyroswiss glass shown in Figure 4 below, when used in conjunction with the above system. The aspect ratio of the glass may be unlimited within these aperture dimensions.

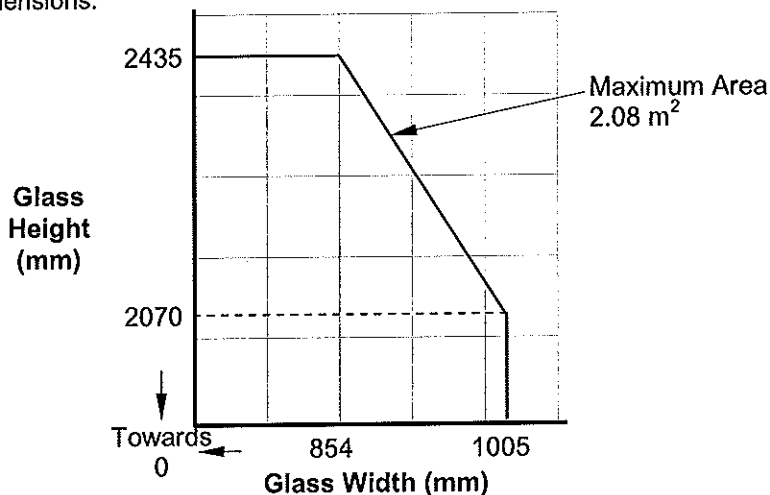

Figure 4.
Maximum Permitted Glass Dimensions



CERTIFICATE No CF 684
VETROTECH SAINT-GOBAIN INTERNATIONAL

SGG PYROSWISS FIRE RESISTING GLASS

SGG Pyroswiss Glass in steel framed screens for periods of 30 minutes integrity

The screens shall be no greater than 4000 mm high unless suitable tie backs and/or fire protected structural supports are provided.

The glass shall be installed into a previously tested framing system (which is covered appropriately by test or assessment evidence or is CERTIFIRE approved) using pressure plate glazing, screw-fixed or clip-on retaining beads, see examples below. The glass shall be glazed into the screen with ceramic fibre gasket on both faces and set on setting blocks which comprise calcium silicate material (or similar) to determine the correct edge cover.

Note: glass used in this application may be laminated, acid etched, tinted, patterned or screen printed subject to the conditions specified on Page 3 of this document.

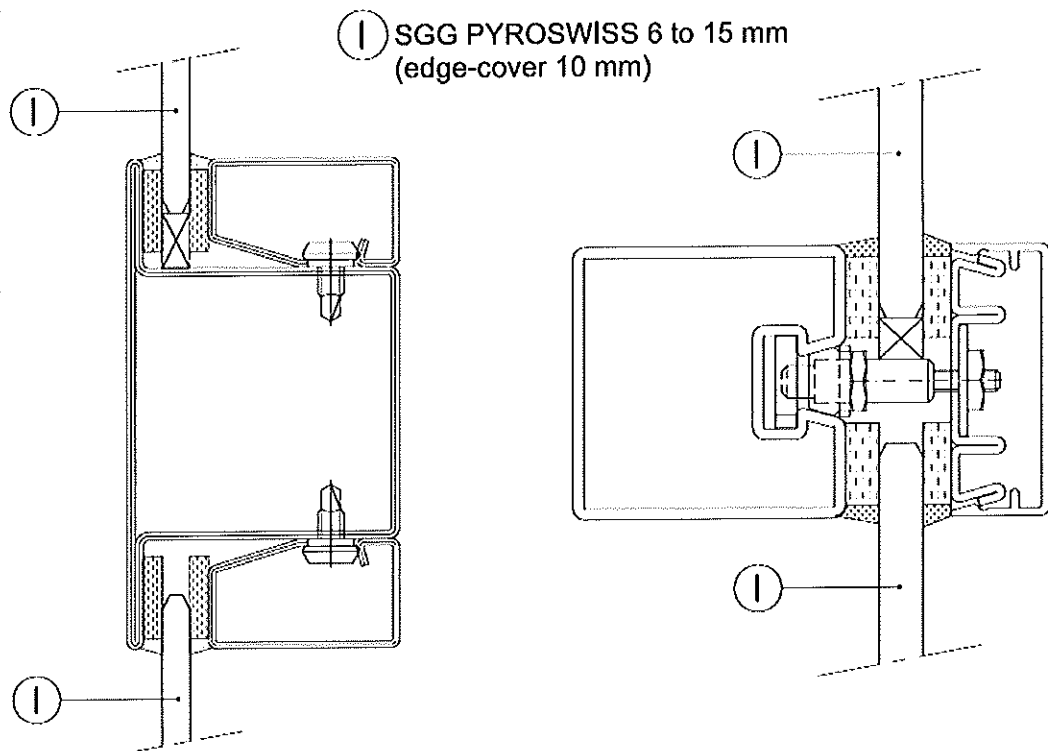



CERTIFICATE No CF 684
VETROTECH SAINT-GOBAIN INTERNATIONAL

SGG PYROSWISS FIRE RESISTING GLASS

SGG Pyroswiss Glass in steel framed screens for periods of 30 minutes integrity (continued)

This Certificate of Approval relates to the sizes of SGG Pyroswiss glass shown in Figure 6 below, when used in conjunction with above systems. The aspect ratio and shape (rectilinear only) of the glass may be unlimited within these aperture dimensions.

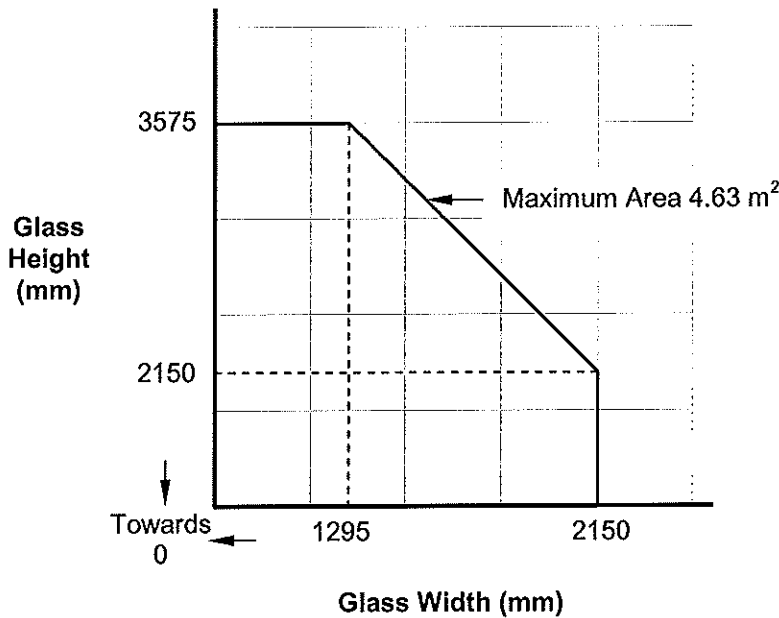

Figure 6.
Maximum Permitted Glass Dimensions



CERTIFICATE No CF 684
VETROTECH SAINT-GOBAIN INTERNATIONAL

SGG PYROSWISS FIRE RESISTING GLASS

SGG Pyroswiss Glass within Double Glazed Units (DGU's) in steel framed screens for periods of 30 integrity

The screens shall be no greater than 4000 mm high unless suitable tie backs and/or fire protected structural supports are provided.

The glass shall be installed into a previously tested framing system (which is covered appropriately by test or assessment evidence or is CERTIFIRE approved) using screw-fixed or clip-on retaining beads. The glass shall be glazed into the screen with ceramic fibre gasket on both faces and set on setting blocks, which comprise calcium silicate material to determine the correct edge cover. Examples of framing systems are shown below.

- ① SGG PYROSWISS 6 or 8 mm (edge-cover 10 mm)
- ② Glass used subject to the conditions specified page 3 (Double Glazing Unit - DGU)

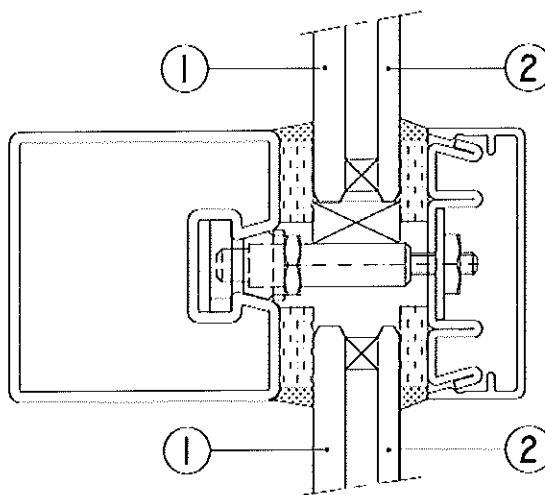
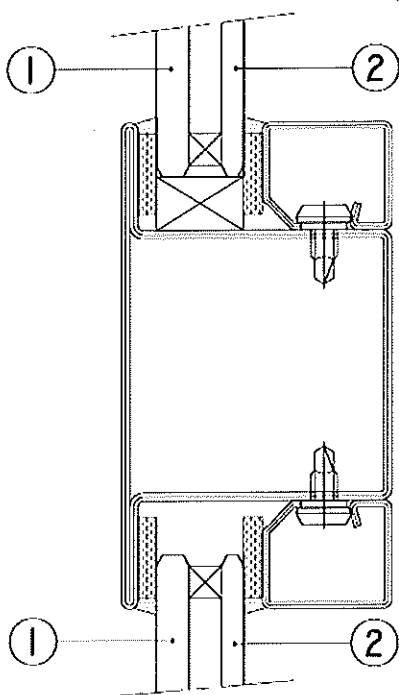

Note: glass used in this application may be laminated, acid etched, tinted, patterned or screen printed subject to the conditions specified on Page 3 of this document.



CERTIFICATE No CF 684
VETROTECH SAINT-GOBAIN INTERNATIONAL

SGG PYROSWISS FIRE RESISTING GLASS

SGG Pyroswiss Glass within Double Glazed Units (DGU's) in steel framed screens for periods of 30 integrity (continued)

Maximum Permitted Pane Dimensions

This Certificate of Approval relates to the sizes of SGG Pyroswiss glass shown in Figure 7, when used in conjunction with above systems. The aspect ratio and shape (rectilinear only) of the glass may be unlimited within these aperture dimensions.

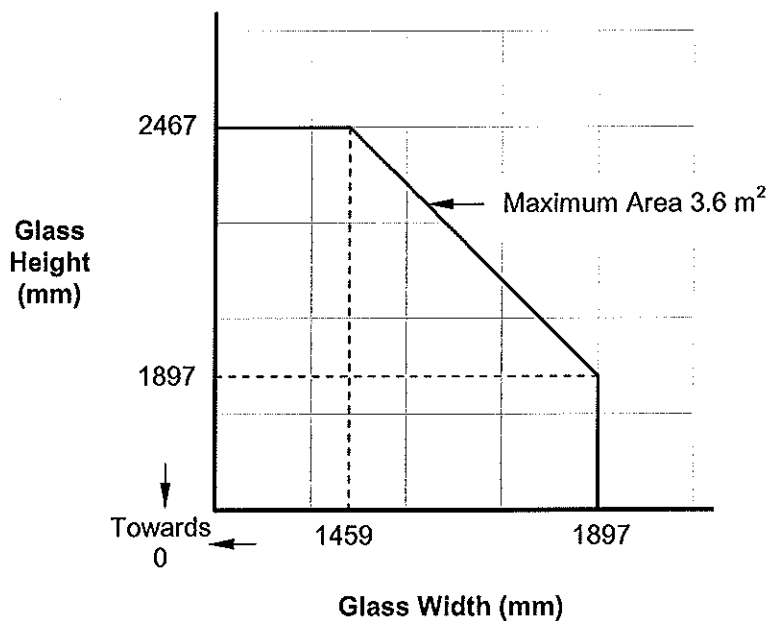

Figure 7.
Maximum Permitted Glass Dimensions